

3. Maintenance and Repair

3.1 Required Measuring Equipment and Accessories

No.	<ul style="list-style-type: none"> ○ Instrument required ● Recommended R&S model 	Type	Order No.
1	<ul style="list-style-type: none"> ○ Signal generator 0.1 - 1000 MHz, 2 V/50 Ω ● Signal Generator 15 Hz - 525 MHz plus 1.05-GHz Frequency Range Extension or 1.05-GHz Frequency Doubler. ● Decade Frequency Generator 10 kHz - 1000 MHz ● Power Signal Generator 25 - 1000 MHz 	SMDU SMDU - B3 SMDU - B5 SMDS SMLU	249.3011... 249.9484.02 275.1312.02 154.8723.52 200.1009...
2	<ul style="list-style-type: none"> ○ Frequency meter 18 - 22 kHz, sensitivity min 10 μV ● SMDU frequency meter (see No. 1) 		
3	<ul style="list-style-type: none"> ○ RF voltmeter 0.1 - 1000 MHz, error < 1% ● RF-DC Millivoltmeter in conjunction with No. 5 	URV	216.3612.02
4	<ul style="list-style-type: none"> ○ Power meter 0.1 - 1 GHz, error < 1% ● Microwave Power Meter with 50-Ω Probe in conjunction with No. 5 	NRS NRS-Z	100.2433.92 100.2440.05
5	<ul style="list-style-type: none"> ○ Digital voltmeter 1 mV - 1 V, 0 - 20 kHz, error < 0.5% 		
6	<ul style="list-style-type: none"> ○ Lowpass filter 60 - 1000 MHz, 30 - 60 dB, 50 Ω 		

No.	<ul style="list-style-type: none"> o Instrument required ● Recommended R&S model 	Type	Order No.
7	<ul style="list-style-type: none"> o 50-Ω attenuators 0 - 1 GHz, 5/10/60 dB 		
8	<ul style="list-style-type: none"> o 50-Ω termination r < 1%, 0 - 1 GHz 		

3.2 Checking the Rated Specifications

3.2.1 Performance Checking

Test setup

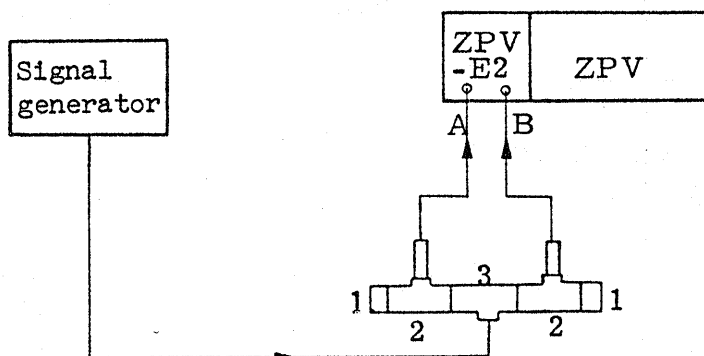

- 1 Termination
- 2 Insertion Adapter ZPV - Z1
- 3 Feed Unit ZPV - Z2

The Tuner ZPV - E2 is inserted into the Vector Analyzer ZPV in accordance with section 2.2.2 and fixed mechanically.

Disconnect the frequency autoranging facility on the basic unit. Set the generator output voltage to 0 V. The red lamp UNSYNC 1 and one of the green lamps associated with the frequency range indication 2 should light up. By pressing buttons 3 and 4 it must be possible to switch over the frequency ranges accordingly in the corresponding order.

Set an output level of about 200 mV unmodulated and any frequency between 0.1 and 1000 MHz on the signal generator. Select the frequency range corresponding to this frequency by hand (button 3 or 4). Now the red lamp UNSYNC should go out and the applied voltage of about 100 mV should be indicated

in both channels on the ZPV (modes A (B), LIN). Check for correct synchronization in all frequency ranges.

Switch on the frequency autoranging facility on the basic unit. It should track the generator frequency over the entire range. Connect a 60-dB/50- Ω attenuator pad between the feed unit and the insertion adapter B. Set the generator frequency to 1 to 10 MHz and the amplitude in channel A to 30 mV. A level of 30 μ V should be indicated for the B channel.

3.2.2 Frequency Dependence of Amplitude Conversion

a) Range 0.1 to 100 MHz

Test setup

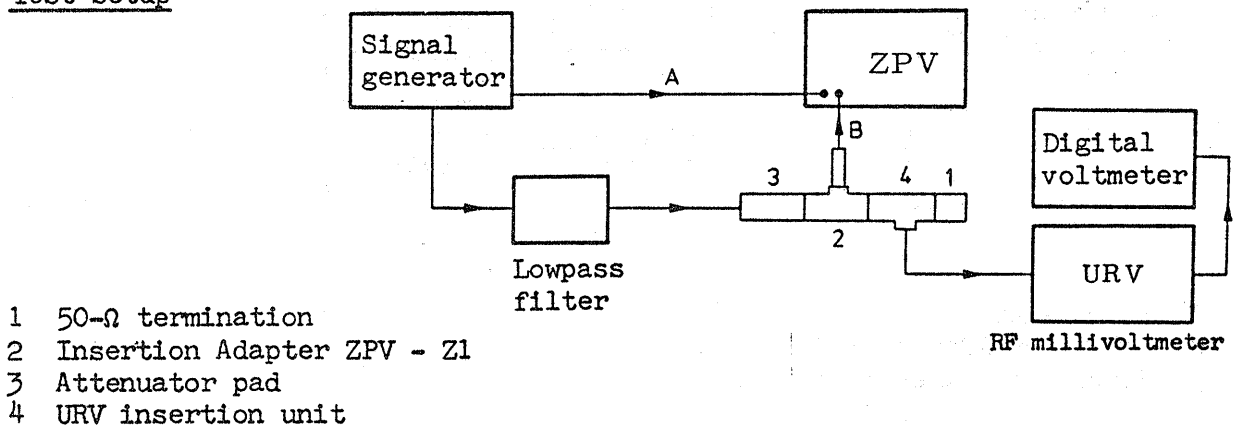

The frequency dependence of the amplitude conversion in the Tuner ZPV - E2 is checked by applying an accurately known signal to its input (probe). The accuracy of the measurement depends on the harmonic content of the calibration signal. To obtain a harmonic suppression of > 30 dB, a lowpass filter is used in the test setup. If an R&S signal generator is used, no lowpass filter is necessary.

- Set 10 MHz on the signal generator (unmodulated).
- Adjust the output level of the signal generator such that the RF millivoltmeter indicates 1 V_{rms}.
- Select the range 6 to 10 MHz on the ZPV - E2. Lamp UNSYNC should go out.
- Set mode B, LIN on the ZPV.
- The indicated value should lie within the tolerance limits given in the specifications.

- Repeat the measurement at 0.1 MHz, 50 MHz and 100 MHz. When measuring at 0.1 MHz the level should be 100 mV.
- Replace probe B by probe A. Select mode A, LIN on the basic unit and repeat the measurements for channel A.

b) Range 100 to 1000 MHz

Test setup

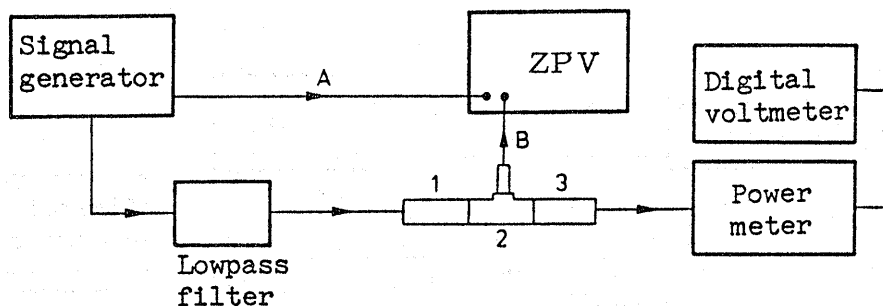

- 1 Attenuator
- 2 Insertion Adapter ZPV - Z1
- 3 Power meter insertion unit

The frequency response is checked with a calibrated signal. To increase the accuracy and to keep the harmonics of the calibrated signal at least 30 dB down, a lowpass filter is used. It can be omitted if one of the recommended signal generators is used. The measurement accuracy then depends on the accuracy of the power meter alone.

- Calibrate the power meter in the 1-mW measuring range in accordance with its operating instructions. To increase the accuracy, the power meter should be used in conjunction with a digital voltmeter and the calibration curve should be taken into account.
- Set the signal generator frequency to 300 MHz. Set the unmodulated output to 1 mW (0 dBm) with the aid of the power meter.
- Select the corresponding frequency range on the basic unit. Lamp UNSYNC should go out.
- Select mode B, LIN.
- Any departure of the indicated value from nominal (= 223.5 mV) should

be within the tolerance limits given in the specifications.

- Repeat the measurement at 500 MHz, 800 MHz and 1000 MHz.
- Carry out the same measurements for channel A.

3.2.3 Differential Phase/Frequency Response

Test setup

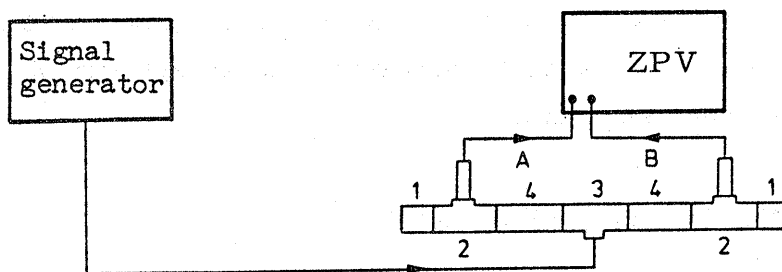

- 1 50- Ω termination
- 2 Insertion Adapter ZPV - Z1
- 3 Feed Unit ZPV - Z2
- 4 10-dB/50- Ω attenuator

The differential phase response of the Tuner ZPV - E2 is measured in a symmetrical test setup.

- Set a reference frequency between 1 MHz and 10 MHz (unmodulated) on the signal generator. The output level is adjusted for 100 mV at the ZPV. Select mode A (or B), LIN.
 - Switch in the frequency autoranging facility on the ZPV.
 - Store the reference phase at the reference frequency (f REF. STORE).
 - Vary the generator frequency over the entire range.
- The phase variation indicated on the ZPV should not exceed the values specified in the data sheet.

3.2.4 Differential Amplitude/Frequency Response

Test setup same as under 3.2.3.

- Set a reference frequency between 1 MHz and 10 MHz on the signal generator (unmodulated). Adjust the output level for 100 mV at the ZPV. The ZPV should be operated in mode A (B), LIN.
- Change the ZPV mode to B/A, LIN. Store the reference level (LEVEL REF. STORE).
- When varying the generator frequency over the entire range from 0.1 MHz to 1000 MHz, the departure from the 100% indication should not exceed the values given in the specifications.

3.2.5 Crosstalk Attenuation of Test Channels

Test setup

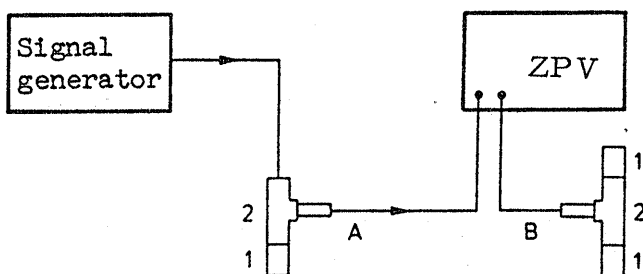

- 1 50- Ω termination
- 2 Insertion Adapter ZPV - Z1

The test signal is applied only to channel A; probe B is terminated with 50 Ω in the insertion adapter. Prior to the measurement, the ratio B/A is calibrated at about 100 mV (mode B/A, dB (REL.)) using the test setup under 3.2.3 and the value is stored (LEVEL REF. STORE).

- Set a frequency of 300 MHz on the signal generator; the output level is 1 V unmodulated.
- The amplitude of the crosstalk signal is indicated in dB on the ZPV.
- Repeat the measurement at 500 MHz, 800 MHz and 1000 MHz. The nominal crosstalk attenuation is given in the specifications.

3.2.6 Inherent Noise

Test setup same as under 3.2.5.

- Select a frequency of 2 MHz on the signal generator. Adjust the generator output level such that about 3 to 10 mV are indicated for reference channel A.
- Select mode B, LIN on the ZPV and disconnect the filter (button FILTER).
- Withdraw probe B from the insertion adapter such that the probe tip no longer makes contact with the inner conductor. The indicated noise voltage should be $< 10 \mu\text{V}$ (typ.).

3.3 Mechanical Maintenance

3.3.1 Probes

The probes should always be dry, clean and undamaged. The screw heads of the probes must be well tightened to protect the thin-film circuit located inside. After unscrewing the protective cap, the thin-film circuit can be withdrawn from the socket and exchanged (Fig. 2-1). When replacing this circuit, make sure that the contact pins are correctly aligned so that the spiral spring in the socket presses sufficiently against the front contact of the substrate. Both the socket and the thin-film circuit are marked with a dot; the dots should face each other. After exchanging the thin-film circuit adjustment in accordance with sections 5.3.1, 5.3.2, 5.3.4 and 5.3.5 is required.

3.3.2 Plug-in

The Tuner is a compact, exchangeable plug-in of the ZPV. To establish perfect contact to the basic unit, the plug-in is fitted with a connector strip and a guiding pin on the rear panel, both elements being freely adjustable to compensate for the tolerances.

4. Circuit Description

The Tuner ZPV - E2 of the Vector Analyzer ZPV converts the input signal received via the probes to the IF over a wide frequency range of 100 kHz to 1000 MHz. In conjunction with the basic unit, the Tuner is synchronized fully automatically over the entire frequency range to the signal in reference channel A. For some special cases manual frequency-range selection is possible with the aid of pushbuttons. Then the instrument is automatically synchronized in the selected subrange.

The signals received via the probes are converted in the ZPV - E2 with the correct phase and amplitude into a fixed IF of 20 kHz. Thanks to the high input impedance of the probes, test item loading is very low. The measured values are evaluated in the basic unit at the fixed IF.

4.1 Frequency Conversion of the Test Signal

See Fig. 4-1 in Appendix.

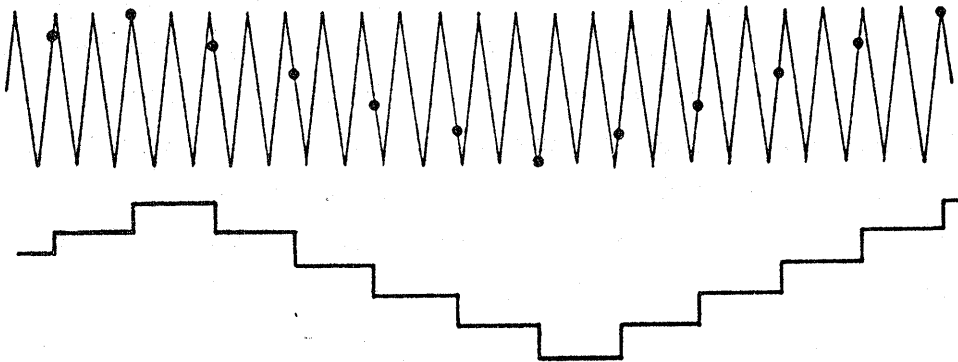

Fig. 4-2 Frequency conversion by sampling

The method of sampling the RF signal used in the Tuner ZPV - E2 permits expansion of the signal with respect to time so that it can be processed at a much lower IF. The expansion is performed by sampling with the correct phase after omitting n periods of the RF signal and storing the information between two sampling points (Fig. 4-2).

The accuracy of the expanded display is determined by the number of sampling points during one period of the represented waveform, i.e. by the ratio of the sampling frequency to the IF.

The sampled voltage is stored in the storage capacitor C_s (Fig. 4-3) which is temporarily connected to the voltage source via switch S. The capacitor charges to the mean value of the voltage applied. During the hold time between two sampling points the storage capacitor is discharged only by the input resistance R_{in} of the subsequent buffer amplifier. The resulting voltage variation is negligible due to the long time constant $C_s \times R_{in}$.

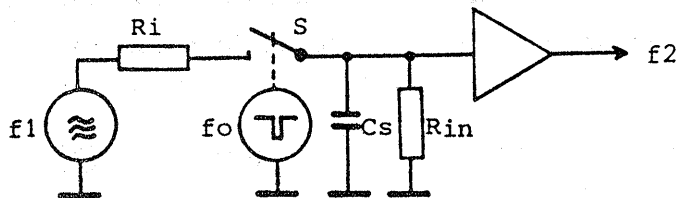

Fig. 4-3 Sampling principle

The frequency f_2 of the converted signal is the difference between n times the scanning frequency f_o and the input frequency f_1 :

$$f_2 = n f_o \pm f_1 \quad (1)$$

To keep the intermediate frequency f_2 constant and independent of the input frequency, the scanning frequency is controlled accordingly. The frequency control circuit compares the nominal with the actual frequency and produces a voltage proportional to the IF deviation. This voltage is processed in the control amplifier Y15 and applied to the variable oscillator Y16 (Fig. 4-1). Its frequency is controlled such that the remaining deviation is reduced to a minimum. The pulse generator driven by the VCO produces narrow pulses which, after symmetrization, are taken to the probes for sampling the input signal. The pulses are produced together for both channels, the phase noise being thus suppressed to a large extent. The required decoupling is achieved by the configuration of the two channels and by the use of diode switches. The adjustable delay network Y19 located between the pulse generator Y12 and the following amplifier B, Y13, is used for compensating the slightly different electrical lengths of the pulse lines associated with the two channels, thus eliminating the frequency dependence of the phase relations during conversion.

As is shown in Fig. 4-1, the input signal is applied to the two probes directly without preselection. Thus a minimum frequency dependence of the RF section is achieved, the high input impedance over the entire frequency range being maintained. The bandwidth of the two channels, which is about 50% of the sampling frequency, is max. 150 kHz. Considering the test bandwidth of the basic unit, this large bandwidth has to be taken into account particularly for measurements on open systems. As mentioned above, each input frequency yields an intermediate frequency which is found from equation (1). Hence any frequency f_x which meets the following conditions can be evaluated:

$$f_x = (n + m) f_o + f_2 + y \quad y \leq B/2 \quad (2)$$

$$n f_o = f_1 + f_2 \quad (3)$$

f_1 = frequency of input signal in channel A

f_o = sampling frequency

f_x = unwanted frequency

f_2 = IF (20 kHz)

B = test bandwidth

$n, m = 0, 1, 2 \dots$

When measuring in closed systems where only the test frequency to which the instrument is synchronized exists, the measuring results cannot be falsified.

4.2 Sampling Probe and Amplifier (Y11, Y13)

See circuit diagram 237.1277 S.

In conjunction with the amplifier (Y11, Y13), the thin-film probe constitutes a complete sampling circuit. The input signal is taken to the diode gate via C1. During the interval between the sampling pulses, the diode gate (GL1, 2, 3, 4) is inhibited by the bias voltages produced in the amplifier (BU25.13, 17). The sampling pulses, which are superimposed on the bias, open the gate for a fraction of a nanosecond. During this interval the capacitor combination C2, C3, C4 is charged in accordance with the voltage applied.

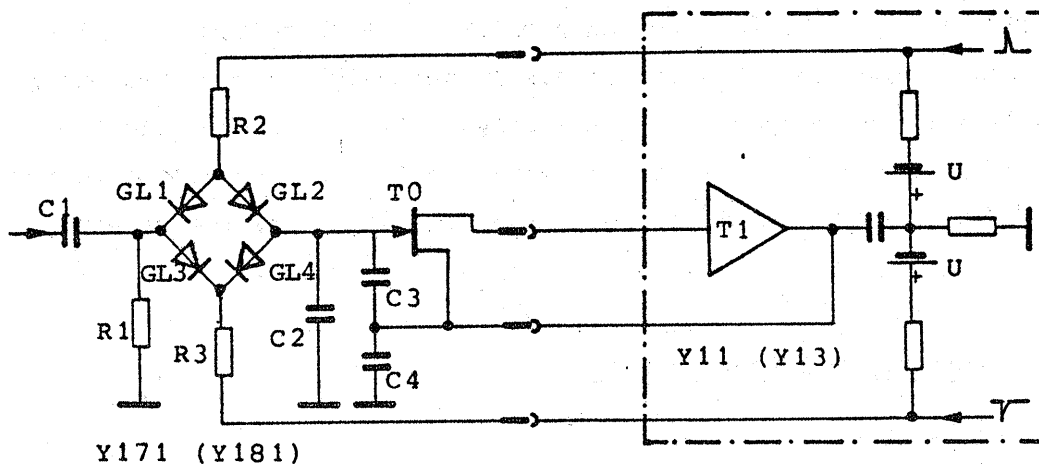

Fig. 4-4 Sampling circuit

During the gate-open time, the capacitors are charged to only a part of the voltage applied. The storage capacitor C_s (Fig. 4-2), which is realized by the configuration C2, C3, C4, is used for restoring the initial amplitude of the signal applied.

The voltage difference occurring across C3 due to the charge applied is amplified by T0 and T1 and returned to the junction point C3, C4. The feedback shifts the difference in charge from C3 to C2. Thus the same voltage is present across C3 as before the sampling procedure, whereas the input voltage with the correct amplitude is available across C4.

The driving of the diode bridge in step with the IF signal via T3 in the amplifier (Y11, Y13) suppresses the nonlinear distortion of the IF signal at higher amplitudes. Resistor R1 (Fig. 4-4) takes the gate of T0 to a defined DC potential during the sampling procedure.

The bias voltages for the diode gate GL1 to 4 are produced in the amplifier. The sum of the two voltages is set with R18 and the symmetry is adjusted with R17 for optimum suppression of the residual pulses at the probe input (C1). The use of a current source T4 for producing the bias further facilitates the adjustment. To ensure proper functioning of the sampling circuit, two symmetrical pulses which arrive at the same time are required. Symmetrization of the negative pulses coming from pulse generator Y12 takes place in the amplifier, where also the bias voltages are superimposed via R21 and R22.

The whole sampling probe is produced on a substrate in thin-film technique (Fig. 2-1) permitting excellent reproducibility. The thin-film circuit is accommodated in the probe tip and is easily accessible after unscrewing the cap. The electrical connection to the plug-in is established via the built-in four-way socket and the corresponding cable. The connection to the probe tip is provided via the front contact on the substrate and an axially arranged spiral spring in the base of the thin-film circuit.

4.3 Automatic Frequency Control

See Fig. 4-1 in Appendix.

The IF signal of channel A is used as the feedback quantity for the automatic frequency control. The AFC controls the frequency of the voltage-controlled oscillator Y16 and thus also the frequency f_0 of the sampling pulses as a function of the IF offset. The IF is obtained from equation (1) (see section 4.1).

The IF signal from the amplifier of channel A, A11, is applied to input ST28.5 of the synchronization subassembly Y14 (circuit diagram 237.1348 S). The signal is amplified and limited in T1 and B1, whereby disturbing amplitude variations are suppressed. The limited signal carrying the frequency information is applied to the coincidence demodulator of B1. This demodulator functions as a switch: the test signal is chopped at the rate of the reference signal. The mean value of the demodulator output voltage (B1.14) is directly proportional to the phase difference between the two signals. The symmetrical configuration of the demodulator largely suppresses the reference signal, which would otherwise produce crosstalk.

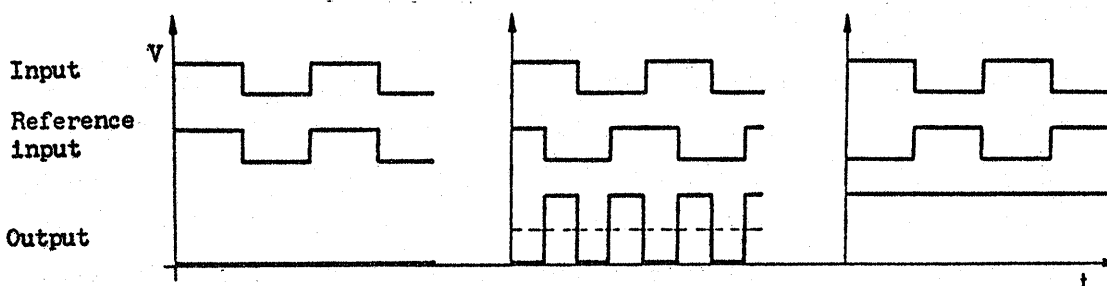

Fig. 4-5 Phase relations at coincidence demodulator B1

The reference signal for the demodulator is produced in the parallel resonant circuit L1-C22, which receives the limited signal coming from B1.8 via the buffer stage T4. The deviation of the IF signal from the resonant frequency is converted into the corresponding phase shift:

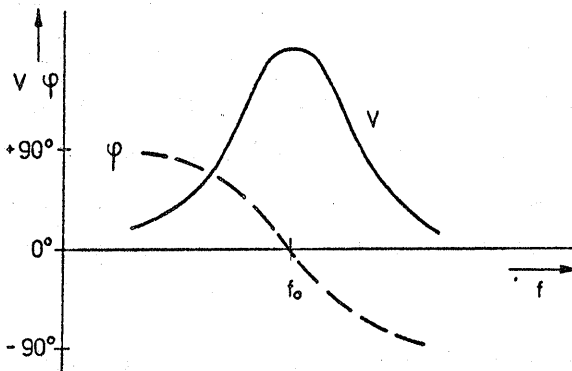
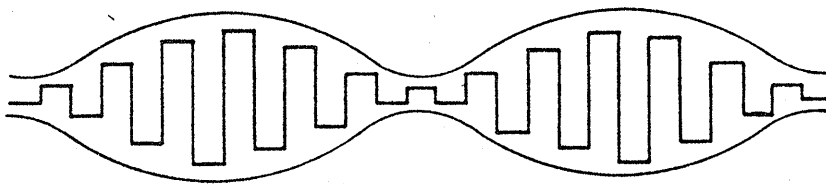

Fig. 4-6 Voltage and phase in the resonant circuit L1-C22

The frequency-dependent amplitude variation of the reference signal is largely suppressed in the diode limiter GL11, GL12, GL13, which is connected after the buffer stage T5. The reference signal is applied to the coincidence demodulator and at the same time used, via C27, as the reference signal for the digital filter in the basic unit. The voltage proportional to the IF deviation is taken, via ST28.15, to the control amplifier Y15 for further processing. The frequency dependence of the amplitude in the resonant circuit is used for obtaining the SYNC bit which is available at ST28.19. The selective amplifier T2 + T3 together with the voltage doubler GL6, 7, 8, 9 produces a voltage used for slowing down the searching oscillator.

During the searching procedure the IF signal applied from the postamplifier to the AFC circuit varies from 0 to $f_0/2$. At the highest IF, the signal is amplitude-modulated by other mixture products, which might disturb the correct functioning of the AFC:



For this reason, only the RF component is filtered at input ST28.7 of the synchronization circuit and the ratio of the two IF components is formed in network T7 - R32. If the RF component exceeds the adjusted value, searching is triggered by T9 and thus a wrong lock-in of the control loop is avoided.

In the ranges 0.1 to 0.3 MHz and 0.3 to 1 MHz the ratio of the scanning frequency to the intermediate frequency decreases as a function of the input frequency. This leads to an additional phase shift due to the dead time of the sampling mixer (Fig. 4-2). At the same time the amplitude of the residual pulses at the synchronization input increases. Transistors T10 and T11 correct the modified dynamic conditions. The switching signal is delivered by subassembly Y16 (VCO).

If no signal is applied to probe A and thus no IF signal is produced, the searching oscillator T1, T2, T7 included in the AFC amplifier (circuit diagram 292.0562 S) sweeps the voltage-controlled oscillator until the AFC loops starts to operate.

When an IF of about 40 kHz is reached, the DC voltage delivered by amplifier T2, T3 in the synchronization subassembly exceeds the switching threshold of transistor T3 in the control amplifier. Thus the discharging current of C11 is reduced considerably. Consequently the sweep speed of the voltage produced in the searching oscillator decreases. During this transition time the resonant circuit L1 - C22 (Y14) determining the IF tunes in and the output voltage of operational amplifier B1 reaches its positive maximum value. Thus the discharging current of C11 in the searching oscillator is taken over by B1 and T3 is inhibited. Since only a low current flows, the sweep speed is reduced (Fig. 4-7).

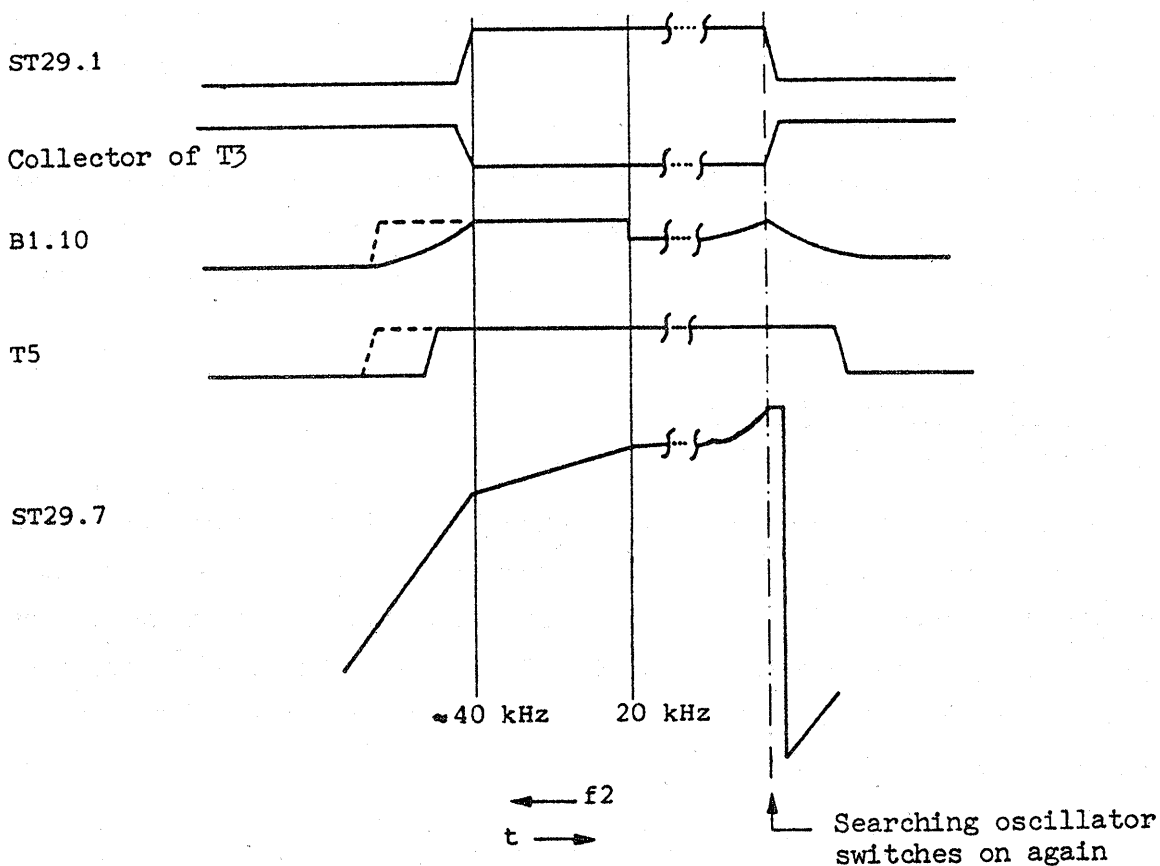

Fig. 4-7 Capture of AFC amplifier Y15

Overlapping of the transition at about 40 kHz is required to avoid disabling of the searching procedure. When the desired IF of 20 kHz is reached, the AFC loop starts to operate, keeping the voltage across C11 at such a value that the difference between n times the scanning frequency and the input frequency yields an IF of 20 kHz. Thus C11 associated so far with the searching time constant now determines the control time constant in conjunction with R18. The voltage across C11 is delivered via impedance transformer T6 and applied as the control voltage to the variable oscillator Y16. If the voltage across C20 falls below the threshold of Schmitt trigger T4, T5, the searching oscillator is switched on again via T3 and the searching procedure recommences. If the AFC loop has to track a signal of decreasing frequency, the voltage across C11 increases up to +0.6 V. When this value is reached, T1 starts to conduct. The voltage variation at the collector of T1 is inverted in T2 and applied, via T7 and C11 - R18, to the base of T1 as a positive feedback signal. During the discharge of the time-constant network R21 - C12, which determines the return sweep of the searching voltage,

C11 is charged to +5 V. The highest voltage across C11 is fixed by the voltage divider R20, GL7, R25. When the trigger threshold of T2 is exceeded, the return sweep is stopped. T2 and T7 start to conduct and T1 is inhibited. Thus the hold range of the AFC loop is limited to about 6 V. Its searching range is equal to the sweep width of the searching sawtooth of 5 V. The wider hold range is of special advantage for sweeping.

For group delay measurements, the AFC loop is brought to a defined state via connector ST29.3 prior to each measurement to ensure that the test signal is synchronized with the same harmonic. The reset pulses are available at the control board.

4.4 Variable Oscillator Y16

See circuit diagram 292.0510 S.

The variable oscillator produces the trigger pulses for the pulse generator. The VCO has to meet relatively stringent requirements with respect to the short-term frequency stability. As is explained in 4.1, the instrument uses harmonic mixing up to more than 1000 MHz. Considering the given IF and the resulting bandwidth of the AFC loop, the short-term stability of the VCO frequency should be at least 5×10^{-6} .

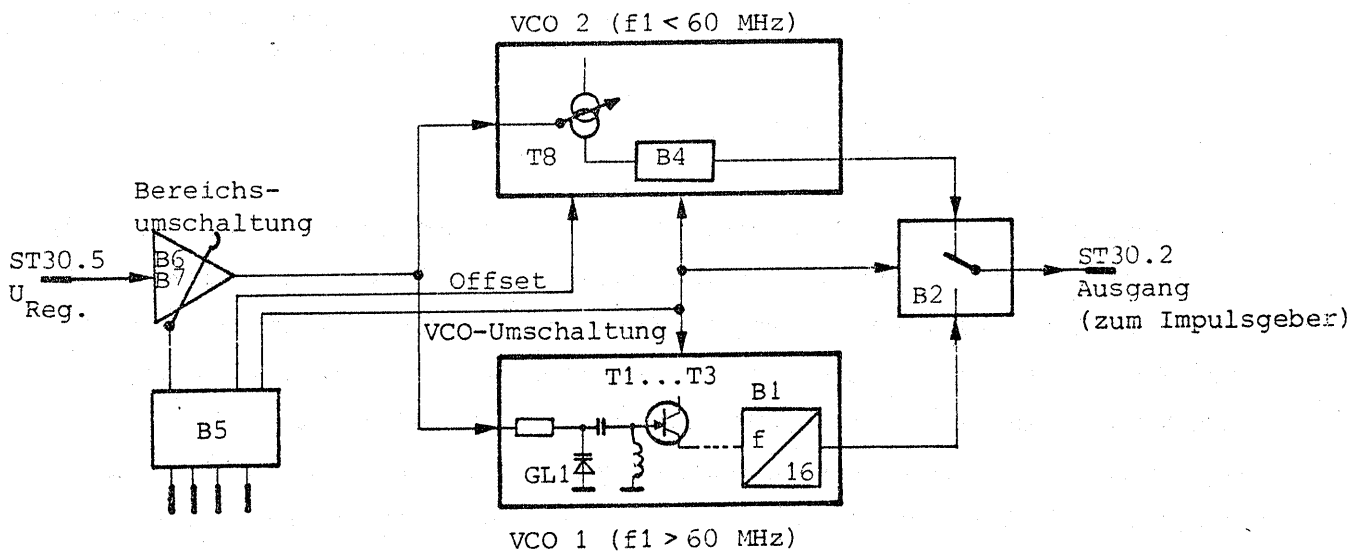

Fig. 4-8 Block diagram of VCO Y16

The variable oscillator Y16 contains the VCO1 used at input frequencies of $f_1 > 60$ MHz and the VCO2 operative at $f_1 < 60$ MHz (see Fig. 4-8).

The control voltage arriving at ST30.5 is taken via B6, B7 to the two VCOs and determines their frequency. Depending on the frequency range, the gain of B7 is switched over via the fixed-value memory B5, which also causes

switchover of the two VCOs (B2, T4). The frequency of VCO1 can be adjusted via varactor GL1. The frequency of the VCO1, divided by 16 (B1), is applied to switch B2. The frequency of VCO2 is determined by the controllable current source T8. For frequencies below 1 MHz, T6 conducts and, in addition to C23, C24 determines the frequency range.

The voltage supply of VCO2 is additionally stabilized with B3, thus reducing the spurious deviation and improving considerably the reproducibility of the VCO control characteristic.

4.5 Pulse Generator Y12

See circuit diagram 237.1290 S.

The pulse generator supplies the two sampling probes with the sampling pulses. Due to the centralized pulse generation the influence of the sampling-pulse phase variations on the differential phase response of the two sampling stages is suppressed to a large extent.

The TTL-level pulses coming from the VCO are differentiated by C1 - R1 and applied to T1. T1 steepens the edges of these pulses and ensures that T2 is driven to a constant output over the entire frequency range. The two transistors T1 and T2 function as avalanche transistors. In this mode the transistors are operated in the region of the first breakdown voltage. With a sufficient driving level applied to the transistor, the critical point of the collector voltage variation is reached, causing a multiplication of the base current and thus the avalanche-like breakdown of the transistor. After the recovery time t_r , the collector voltage V_C increases exponentially until it reaches the supply voltage V_B .

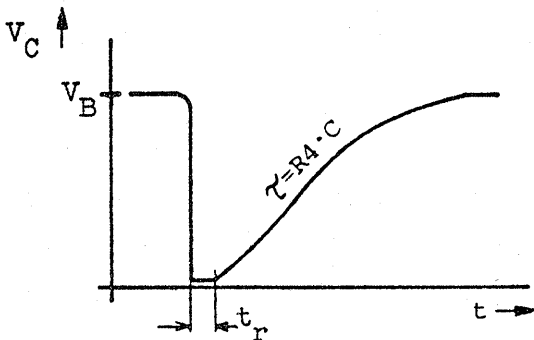

Fig. 4-9 Voltage characteristic at the collector of T2

The abrupt rolloff of the collector voltage is differentiated by C3 (C4) and, after symmetrization, applied to the sampling stages via diode switches GL52 and GL53. These diode switches ensure sufficient decoupling of the two channels. Due to the current injected by the pulse generator via R8 (R7) the shunt diode GL1 (Fig. 4-10) conducts. The voltage drop across GL1 inhibits diode GL2; it is made conductive only by the negative pulses coming from the pulse generator.

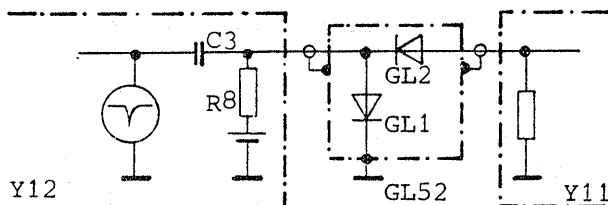

Fig. 4-10 Application of the scanning pulses via diode switches (component Nos apply to channel A)

4.6 Control Board Y22

See circuit diagram 301.7360 S.

The control board permits a certain frequency subrange to be switched in. The four-bit counter B4 gives the selected range in binary coding. The count can be manually increased and decreased via the control lines ST35.a9, b9, using the two front-panel buttons 3 and 4. In addition, the counter can be set at will by the microprocessor of the basic unit via the data lines ST33.a6, a5, a4, a3 and the strobe line St33.b4. B5 and B6 decode the count and drive the LEDs for indicating the frequency subrange on the LED board Y21 as well as the level converters T2 to T15.

For group delay measurements, B7 delivers a reset pulse for the AFC loop prior to each measurement to ensure synchronization with the same harmonic. Both the count and the plug-in identification with the synchronization bit can be taken to the data bus via B10 and the bus driver B11 and read in by the processor.

Since only 14 of the binary combinations 0 to 15 are associated with the frequency subranges, the microprocessor monitors via data lines - depending on the plug-in - the count and causes the unused counter combinations to be omitted. In this way switching through the 14 subranges is possible in both directions.

BII and BIII are used for locking the two pushbuttons 3 and 4 in the case of remote control and for extinguishing the frequency range indicators when the autoranging facility is used.

5. Repair

5.1 Required Measuring Instruments and Accessories

The measuring instruments listed under 3.1 are required. In addition, the following equipment is necessary:

- Squarewave generator, 100 to 200 kHz, V_{out} 20 mV_{pp}
- Oscilloscope, 0 to 30 MHz, vert. 1 mV/cm, horiz. 0.5 μ s to 20 ms

5.2 Assembly

Prior to inserting the Tuner fix its bottom cover and remove the upper cover of the basic unit ZPV. The guiding pin and the connector strip ST42 on the rear panel of the plug-in should be adjusted such that perfect insertion and reliable contact making are ensured. Tighten the nuts of the phase shifter Y19 such that the rotor disk can be turned. Then insert the plug-in into the basic unit and fit the different subassemblies.

After unscrewing the probe tip, the thin-film circuit with the spiral spring in the base is inserted in accordance with the markings. The contact pins should not be bent. Free movement of the thin-film circuit along its axis should be possible. The spring should press against the circuit such that good contact with the probe tip is ensured. If necessary, adjust the contact pins accordingly. Then screw the probe cap into place.

5.3 Adjustments

The position of the subassemblies and adjustment controls is shown in Fig. 5-1 (in the Appendix).

Prior to the adjustment check the supply voltages +20 V \pm 10 mV, -20 V \pm 10 mV and 120 V \pm 0.5 V according to section 5.2.1 of the manual for the ZPV basic unit and adjust, if not within tolerances. The load resistors referred to in the above mentioned section of the ZPV manual are not required if the Feed Unit ZPV-E2 is fitted and the frequency range 600 to 1000 MHz is selected.

5.3.1 Sampling Stages

Test setup

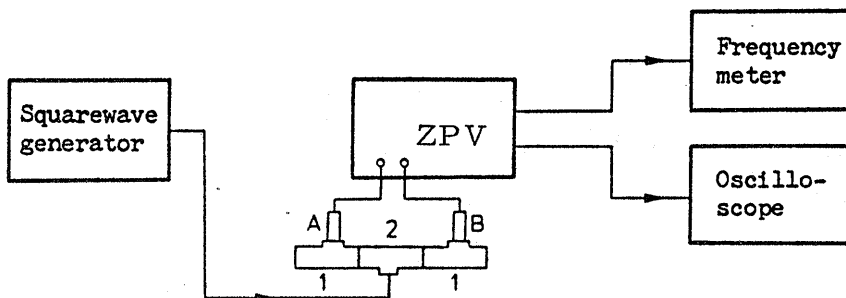

- 1 Insertion Adapter ZPV - Z1
- 2 Feed Unit ZPV - Z2

Preliminary adjustment of amplifier Y11, Y13

Select the manual frequency range selection on the basic unit ZPV. The indicator **FREQ. STOP AUTORANGING** should light up. As well, one of the green LEDs associated with the frequency subrange indication should light up.

Buttons 3 and 4 should permit successive selection of the frequency subranges in the correct order. For further adjustments, select the range 600 - 1000 MHz. Use the oscilloscope to check the correct functioning of the VCO Y16 and of the pulse generator Y12. To this effect, apply the probe of the oscilloscope close to transistor T2 in the pulse generator and set R12 to mid-position. Steep negative-going pulses of about 3 MHz appear on the screen. If the pulses are missing, check the VCO output (ST30.2) and input (ST30.5). The signal at pin 5 should be a sawtooth of about 5 V and that at pin 2 a square wave of $\geq 3 V_{pp}$ on which a +5-V bias is superimposed. For measuring connect the board via one of the two adapter boards which are included in the ZPV. However, these boards cannot be used for pulse measurements on Y11, Y12 and Y13. Also use the oscilloscope to check whether a DC voltage of +0.6 V is present at the output (K27) of phase shifter Y19. If required, turn the rotor of the phase shifter accordingly.

Select a frequency of about 200 kHz with the duty cycle 2 (period/mark ratio) on the squarewave generator. The voltages across the probes A and B should be $100 mV_{pp}$. Connect the oscilloscope to the cursor of R3 in the amplifier Y11 and turn R3 to the lefthand stop. Use R18 to set the bias and

R17 to coarsely adjust the symmetry such that the waveform at R3 corresponds to that at the probe tip. In the case of a wrong adjustment, the IF signal is distorted:

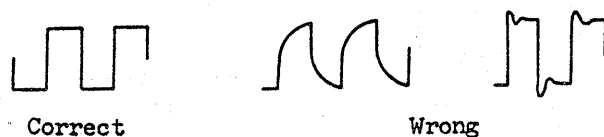

Connect probe A of the ZPV - E2 directly to the oscilloscope and use R17 in the amplifier Y11 to adjust the minimum of the residual pulses at the probe tip; their amplitude should not exceed 10 mV_{pp} . Reinsert the probe into the insertion adapter and use R3 to adjust for the same amplitude of the IF voltage as at the probe tip.

Amplifier Y13 associated with channel B is adjusted in the same way.

5.3.2 Synchronization Circuit Y14 and AFC Amplifier Y15

The same test setup as under 5.3.1 is used. The squarewave generator is replaced by a sinewave generator ($f = 5 \text{ kHz to } 2 \text{ MHz}$).

Set the frequency of the generator to 20 kHz and its output voltage to about 300 mV. Connect the oscilloscope to the base of T5 in the synchronization circuit Y14 and use L1 to adjust the voltage maximum.

Connect the oscilloscope to the collector of T3 in the AFC amplifier Y15. Use R8 (Y15) to adjust for a voltage of -2 V at R22. This stops the searching oscillator.

When reducing the input frequency below 5 kHz, the searching oscillator should remain in circuit. When increasing the signal generator frequency above 20 kHz, the searching frequency of about 100 Hz (adjustable with R22) is switched over to a few hertz. Increasing the generator frequency still further brings the searching frequency again to the value adjusted with R22 (the capture mode of the AFC loop is explained under 4.3). However, the switchover of the searching frequency should not occur below 24 kHz. In the range from the slowing down of the searching procedure to 20 kHz, the searching oscillator should not be disconnected.

Connect the oscilloscope to ST29.7 and vary the signal generator frequency over the range from about 100 kHz to 5 kHz. The searching frequency should be reduced in any case at 24 kHz and at 20 kHz the searching procedure should be stopped. In the case of slow searching the output voltage at B1.10 (Y15) should be at least +8 V. At a generator frequency of < 20 kHz searching should be enabled again.

Set the frequency of the generator to 1.4 MHz and its output voltage to about 200 mV. The red lamp UNSYNC on the front panel should light up. Select the frequency range 1 to 2 MHz using the corresponding pushbuttons. Now the red indicator should go out. Connect the frequency meter to the IF output of channel B ($Z_{out} = 1 \text{ k}\Omega$).

Use L1 in the synchronization circuit Y14 to adjust for 20 kHz ± 10 Hz in accordance with the frequency meter. Connect the oscilloscope to the output of operational amplifier B1 (= C6, C9) in the AFC amplifier Y15. Use L1 and L2 to adjust for maximum suppression of the 40-kHz and 20-kHz signals at this checkpoint.

5.3.3 Amplifiers Y11, Y13

Test setup

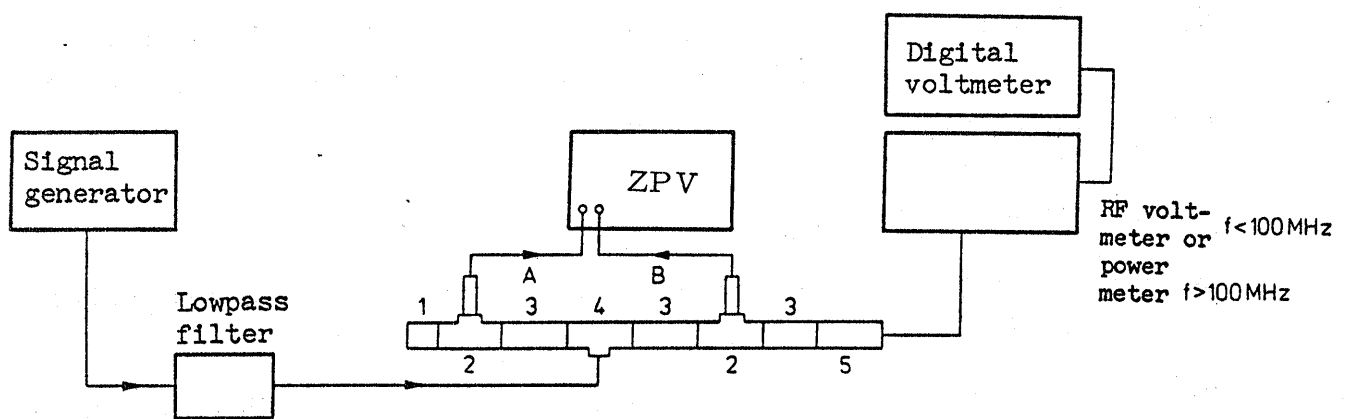

- 1 50- Ω termination
- 2 Insertion Adapter ZPV - Z1
- 3 10-dB/50- Ω attenuator
- 4 Feed Unit ZPV - Z2
- 5 RF voltmeter probe ($f < 100 \text{ MHz}$)
or power meter probe ($f > 100 \text{ MHz}$)

Set the signal generator frequency to 2 MHz. Adjust the level to 31.6 mV in accordance with the RF voltmeter. Select the range 2 to 3 MHz on the Tuner ZPV - E2 and mode B, LIN on the basic unit ZPV. Disconnect the insertion adapter with probe B from the feed unit. Lamp UNSYNC should not light up. The ZPV indicates only the inherent noise. Withdraw the probe from the adapter such that the tip does not make contact with the inner conductor. The indicated noise should not exceed 10 μ V (typ.). If necessary, use R12 in the pulse generator Y12 to adjust for minimum noise. Restore the test setup shown in the above figure. Select the modes A (B), LIN. The indicated values should be 100 mV. If required, adjust R3 in the amplifier Y11 or Y13.

The RF voltmeter with the 10-dB attenuator is replaced by the Microwave Power Meter NRS. When using different power meters, the attenuator should remain in circuit and be considered for the measurement. Set a signal generator frequency of 900 MHz, connect the lowpass filter accordingly and adjust the signal generator level such that the power meter indicates 0.2 mW. Select the range 600 to 1000 MHz on the ZPV - E2. In the mode B, LIN use R18 (Y13) to adjust for 100 mV on the display and check the setting of R17 (see under 5.3.1 "preliminary adjustment of amplifier"). Perform the same adjustments for channel A.

Set the signal generator frequency to 500 MHz and check the calibration. Replace the power meter by the voltmeter and verify the calibration at 100 kHz and 300 kHz with an input voltage of 100 mV. The deviations should not exceed the values given in the specifications.

5.3.4 Phase Shifter Y19

The test setup is the same as under 5.3.3. The power meter is replaced by a 50- Ω termination.

Select the autoranging mode and the measuring mode A (B), LIN on the basic unit. Set the frequency of the signal generator to 1 MHz and its level to 100 to 200 mV in accordance with the ZPV indication.

Store the reference phase using button φ REF. STORE.

Increase the generator frequency to 800 to 900 MHz and adjust the indicated phase to 0^o using phase shifter Y19. After the adjustment, the nuts of the phase shifter should be well tightened. Next check the phase response, referred to 1 MHz, over the entire frequency range. The deviations should not exceed the values given in the specifications.

5.3.5 Differential Amplitude/Frequency Response

The test setup is the same as under 5.3.3

Set the frequency of the signal generator to 1 MHz and the level to 100 mV in accordance with the ZPV indication. Select mode B/A, LIN. Store the reference value using button LEVEL REF. STORE. Check the ratio of the two voltages over the entire frequency range. The test results should meet the requirements of the specification.

5.3.6 Channel Crosstalk

See section 3.2.5.

5.3.7 VCO Ranges

The test setup is the same as under 5.3.2.

VCO 2

Select the frequency range 0.3 to 1 MHz on the ZPV - E2. Reduce the signal generator frequency from 1 MHz to 250 kHz. The set should be synchronized to at least 300 kHz. Increase the frequency starting at about 250 kHz until synchronization is effective again. The frequency at which lamp UNSYNC goes out should not exceed 300 kHz. If necessary, use C24 for correction.

VCO 1

Select the frequency range 60 to 100 MHz on the ZPV - E2. Set the signal generator frequency to 60 MHz and reduce it continuously. When resynchronizing the frequency control (lamp UNSYNC lights up briefly), no reception gap should occur, i.e. lamp UNSYNC should not be on continuously and no permanent searching should be measured at ST30.5. If necessary, use R5 for correction.

1914

1915

1916

1917

1918

1919

1920

1921

1922

1923

1924